

Rotating & Traversing Seat



Since its certification and release into service in 2000, the Martin-Baker Rotating and Traversing Seat has been selected for applications including Police and EMS installations on the following platforms:

- ▼ Airbus EC135 & EC145
- ▼ Airbus UH-72
- ▼ Bell 412

OVER 1,400 ROTATING & TRAVERSING SEATS SOLD TO DATE



Martin-Baker Rotating & Traversing Seat

This class leading lightweight seat offers the user 360° rotation that can be locked in intermediate positions. It traverses fore/aft on MS33601 track or track embedded in aircraft specific floor pallets. Attachment fittings allow installation or removal in less than a minute without tools. It is certified to meet TSO C127a criteria and is now operational in Airbus EC135 & EC145, Airbus UH-72 and Bell 412.

The energy attenuation technology offered by Martin-Baker effectively absorbs the energy from heavy or crash landings, reducing the forces transmitted to the occupant to a survivable level as defined by TSO C127a specification.

The standard seat has optional headrest, armrests, a four-point single-click harness with rotary quick-release buckle, black harness and blue fabric covers. Other optional features can be introduced to suit operator requirements such as fabric type and colour and harness colour.

The seat integrates to the aircraft floor with standard MS33601 floor track with 15" centres.

Seat functional features and aircraft integration options offer optimum flexibility in aft cabin design and configuration.

- ▼ Rotates 360° in 15° increments
- ▼ Traverses fore and aft
- ▼ Integrates directly into cabin floor rails
- ▼ Installed or removed in less than a minute
- ▼ Ideal for aircraft with low cabin heights



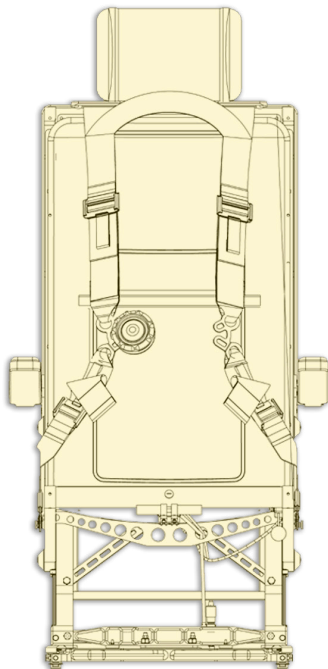
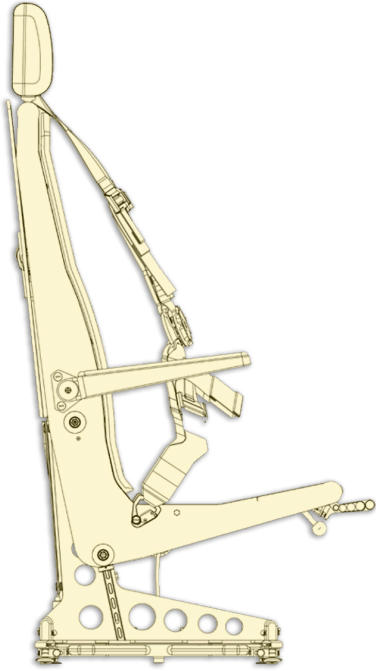
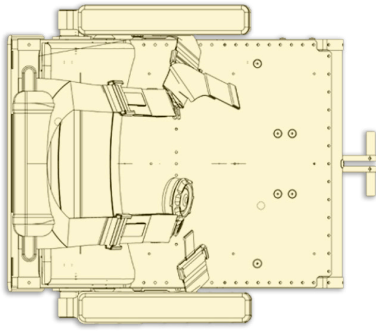

Specification Summary*

Certification: ETSO/TSO C-127a

Options:

- Headrest
- Armrest
- 4 point 1 click harness or 4 point 3 click harness

Certified Seat Weight: 32.30 lbs (Max. Certified Seat Weight)*

Installation: MS33601 heavy duty aircraft track

Installation Direction: Forward or Rear Facing Seat

Harness: 4 pt. locking harness, certified to TSO-C114

Adjustments: Rotation (360° in 15° increments)

Performance: AS8049A, 50th percentile male, load during TTOL:

- Static: 16.0g Forward, 8.0g Lateral, 4.0g Upward, 20.0g Downward
- Dynamic: 30.0g Down, 18.4 Forward

Upholstery: Options including medical covers

* In line with TSO C127a Type B (fore and aft facing) requirements

* Weight dependant on options



MB Martin-Baker

Martin-Baker Aircraft Company Limited, Higher Denham, Near Uxbridge, Middlesex, UB9 5AJ, England
Telephone +44 (0) 1895 836658 Fax +44 (0) 1895 832587
info@martin-baker.co.uk
www.martin-baker.com

Engineering For Life
www.martin-baker.com

© 2024 Martin-Baker Aircraft Company Limited. The contents of this document include intellectual property of Martin-Baker Aircraft Company Limited or its affiliates (Martin-Baker).
Copyright or use of any part without the express written authorisation of Martin-Baker is strictly prohibited.
NDA must be in place before information is shared.